

CG And Receiver Assembling

The ideal C.G. position is 80~85mm behind the leading edge measured at where the wing meets the fuselage. In order to obtain the C.G. specified, add weight to the fuselage or move the battery position. Check the C.G. before flying.

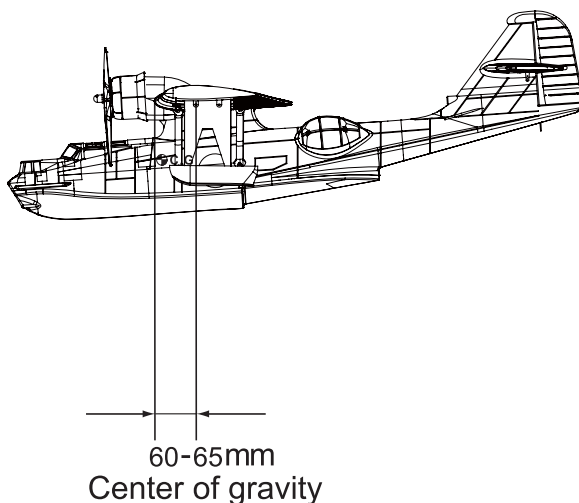

SUGGEST CONTROL THROW SETTING

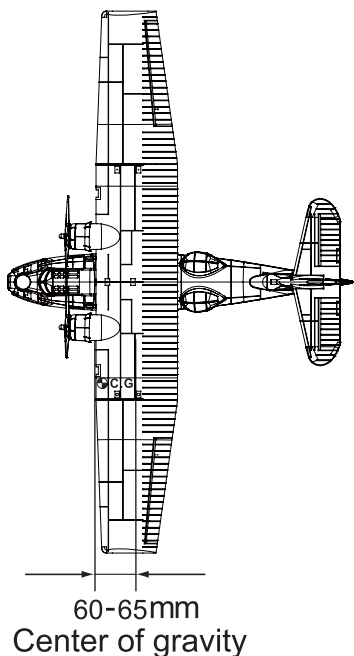
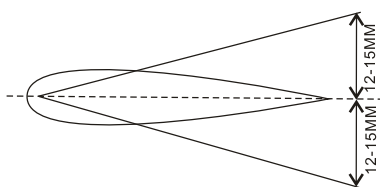

ELEVATOR

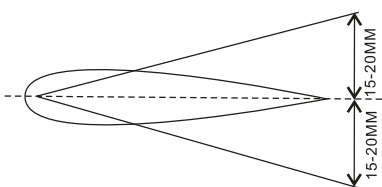

AILERON

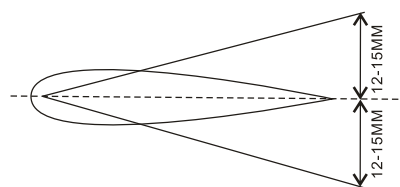

RUDDER

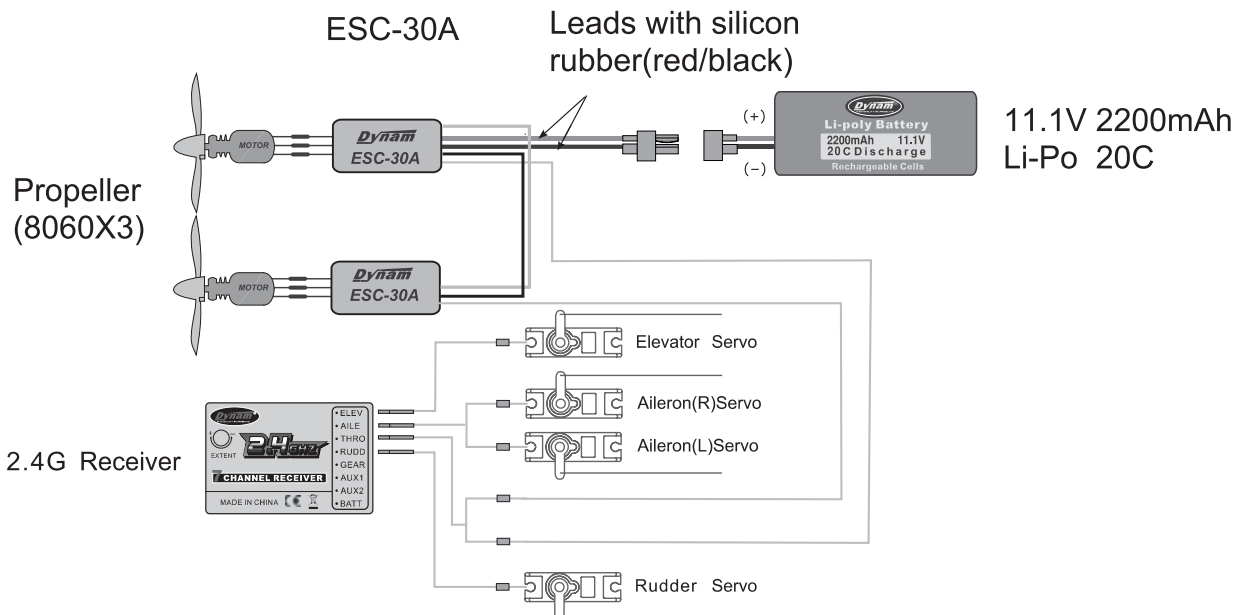

Manual of Brushless Motor Speed Controller

Specifications:

Pentium Series											
Class	Model	Cont. Current	Burst Current (>10s)	BEC Mode (Note1)	BEC Output	Battery Cell		User Programmable	Balance Discharge Protection	Weight	Size
						Li-ion Li-poly	NiMH NiCd				L*W*H
12A	Esc-12	12A	15A	Switch	5V/3A	2-4	5-12	Available	N/A	19g	45*24*9
18A	Esc-12	18A	22A	Switch	5V/3A	2-4	5-12	Available	N/A	19g	45*24*11
25A	Esc-25	25A	35A	Switch	5V/3A	2-4	5-12	Available	N/A	22g	45*24*11
30A	Esc-30	30A	40A	Switch	5V/3A	2-4	5-12	Available	N/A	25g	45*24*11
40A	Esc-40	40A	55A	Switch	5V/3A	2-6	5-18	Available	N/A	35g	55*28*12
50A	Esc-50	50A	80A	Switch	5V/3A	2-6	5-18	Available	N/A	60g	70*31*14
60A	Esc-60	60A	80A	Switch	5V/3A	2-6	5-18	Available	N/A	60g	70*31*14
70A	Esc-70	70A	100A	Switch	5V/3A	2-6	5-18	Available	N/A	62g	70*31*14
80A	Esc-80	80A	100A	Switch	5V/3A	2-6	5-18	Available	N/A	62g	70*31*14

Wiring Diagram:

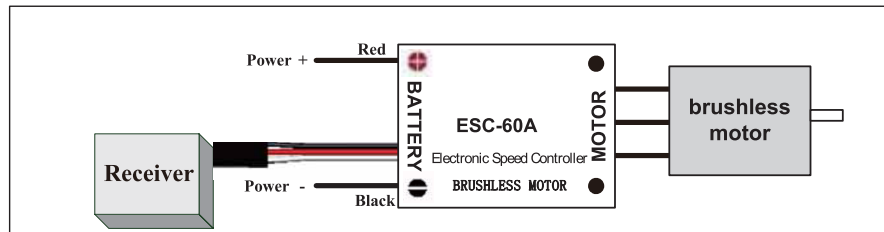

Programmable Items:

- Brake Setting:** Enabled / Disabled, default is Disabled
- Battery Type:** Li-xx(Li-ion or Li-poly) / Ni-xx(NiMH or NiCd), default is Li-xx.
- Low Voltage Protection Mode(Cut-Off Mode):** Soft Cut-Off (Gradually reduce the output power) or Cut-Off (Immediately stop the output power). Default is Soft Cut-Off.
- Low Voltage Protection Threshold(Cut-Off Threshold):** Low / Medium / High, default is Medium.
 - ◆ **When NOT using balance discharge monitoring and protection function** (i.e. **Not** plugging the balance charge connector into the BDMP socket on the Guard series ESC, the ESC only monitors the voltage of the whole battery pack)
 - For lithium batteries, the number of battery cells is calculated automatically. Low / medium / high cutoff voltage for each cell is: 2.6V/2.85V/3.1V. For example: For a 3 cells lithium pack, when "Medium" cutoff threshold is set, the cut-off voltage will be: 2.85*3=8.55V.
 - For nickel batteries, low / medium / high cutoff voltages are 0%/45%/60% of the startup voltage (i.e. the initial voltage of battery pack), and 0% means the low voltage cut-off function is disabled. For example: For a 10 cells NiMH battery, fully charged voltage is 1.44*10=14.4V, when "Medium" cut-off threshold is set, the cut-off voltage will be: 14.4*45%=6.5V.
 - ◆ **When using balance discharge monitoring and protection function** (i.e. Plugging the balance charge connector on battery pack into the BDMP socket on the Guard series ESC, the ESC monitors not only the voltage of the whole battery pack but also the voltage of each cell). For lithium battery, low / medium / high cut off voltage for each cell is: 2.6V/2.85V/3.1V. When the voltage of any cell in battery pack is lower than the cut-off threshold, the protection function is activated.
- Startup Mode:** Normal /Soft /Super-Soft, default is Normal.
Normal is preferred for fixed-wing aircraft. Soft or Super-soft are preferred for helicopters. The initial acceleration of the Soft and Super-Soft modes are slower in comparison, usually taking 1 second for Soft startup or 2 seconds for Super-Soft startup from initial throttle advance to full throttle. If the throttle is closed (throttle stick moved to bottom) and opened again (throttle stick moved to top) within 3 seconds of the initial startup, the restart-up will be temporarily changed to normal mode to get rid of the chances of a crash caused by slow throttle response. This special design is very suitable for aerobatic flight when quick throttle response is needed.
- Timing:** Low / Medium / High, default is Low. *Note2*
Usually, low timing value can be used for most motors. We recommend the **Low** timing value for 2 poles motor and **Medium** timing value for motors with more than 6 poles to get a high efficiency. For higher speed, **High** timing value can be chosen.

Note2: After changing the timing setting, please test your RC model on ground prior to flight!

Begin To Use Your New ESC

Please start the ESC in the following sequences:

- Move the throttle stick to the bottom position and then switch on the transmitter.
- Connect the battery pack to the ESC, the ESC begins the self-test process, a special tone "♪ 123" is emitted, which means the voltage of the battery pack is in normal range, and then N "beep" tones will be emitted, means the number of lithium battery cells. Finally a long "beep-----" tone will be emitted, which means self-test is OK, the aircraft/helicopter is ready to go flying.
 - ◆ If nothing is happened, please check the battery pack and all the connections;

Manual of Brushless Motor Speed Controller

- ◆ If a special tone “ ♪ 567i2” is emitted after 2 beep tones (“beep-beep-”), means the ESC has entered the program mode, it is because the throttle channel of your transmitter is reversed, please set it correctly;
 - ◆ If the very rapid “beep-beep-, beep-beep-” tones is emitted, means the input voltage is too low or too high, please check your battery’s voltage.
3. **“VERY IMPORTANT !”** Because different transmitter has different throttle range, we strongly suggest you using the “Throttle Range Setting Function” to calibrate throttle range. Please read the instruction on page 4-----“Throttle Range Setting”.

Alert Tone

1. Input voltage is abnormal: The ESC begins to check the voltage when the battery pack is connected, if the voltage is not in the acceptable range, such an alert tone will be emitted: “beep-beep-, beep-beep-,beep-beep-” (Every “beep-beep-” has a time interval of about 1 second.)
2. Throttle signal is abnormal: When the ESC can’t detect the normal throttle signal, such an alert tone will be emitted: “beep-, beep-, beep-”. (Every “beep-” has a time interval of about 2 seconds)
3. Throttle stick is not in the bottom position: When the throttle stick is not in bottom (lowest) position, a very rapid alert tone will be emitted: “beep-, beep-, beep-”. (Every “beep-” has a time interval of about 0.25 second.)

Protection Function

1. Abnormal start up protection: If the motor fails to start within 2 seconds of throttle application, the ESC will cut-off the output power. In this case, the throttle stick **MUST** be moved to the bottom again to restart the motor. (Such a situation happens in the following cases: The connection between ESC and motor is not reliable, the propeller or the motor is blocked, the gearbox is damaged, etc.)
2. Over-heat protection: When the temperature of the ESC is over 110 Celsius degrees, the ESC will reduce the output power.
3. Throttle signal loss protection: The ESC will reduce the output power if throttle signal is lost for 1 second, further loss for 2 seconds will cause its output to be cut-off completely.

Program Example

Setting “Start Mode” to “Super-Soft”, i.e. value #3 in the programmable item #5

<p>1. Enter Program Mode Switch on transmitter, move throttle stick to top position, connect battery pack to ESC, wait for 2 seconds, “beep-beep” tone should be emitted. Then wait for another 5 seconds, special tone like ‘♪ 567i2” should be emitted, which means program mode is entered.</p>
<p>2. Select Programmable Items Now you’ll hear 8 tones in a loop. When a long “beep-----” tone is emitted, move throttle stick to bottom to enter the “Start Mode”</p>
<p>3. Set Item Value (Programmable Value) “Beep-”, wait for 3 seconds; “Beep-beep-”, wait for another 3 seconds; then you’ll hear “beep-beep-beep”, move throttle stick to top position, then a special tone “ ♪ i5i5” is emitted, now you have set the “Start Mode” item to the value of “Super-Soft”</p>
<p>4. Exit Program Mode After the special tone “ ♪ i5i5”, move throttle stick to bottom within 2 seconds.</p>

Trouble Shooting

Trouble	Possible Reason	Action
After power on, motor does not work, no sound is emitted	The connection between battery pack and ESC is not correct	Check the power connection. Replace the connector.
After power on, motor does not work, such an alert tone is emitted: “beep-beep-, beep-beep-,beep-beep-” (Every “beep-beep-” has a time interval of about 1 second)	Input voltage is abnormal, too high or too low. The balance charge connector is not located properly in BDMP adapter.	Check the voltage of battery pack Check the connection of the balance charge connector and the BDMP adapter.
After power on, motor does not work, such an alert tone is emitted: “beep-, beep-, beep- ”(Every “beep-” has a time interval of about 2 seconds)	Throttle signal is irregular	Check the receiver and transmitter Check the cable of throttle channel
After power on, motor does not work, such an alert tone is emitted: “beep-, beep-, beep-” (Every “beep-” has a time interval of about 0.25 second)	The throttle stick is not in the bottom (lowest) position	Move the throttle stick to bottom position
After power on, motor does not work, a special tone “ ♪ 567i2” is emitted after 2 beep tone (beep-beep-)	Direction of the throttle channel is reversed, so the ESC has entered the program mode	Set the direction of throttle channel correctly
The motor runs in the opposite direction	The connection between ESC and the motor need to be changed.	Swap any two wire connections between ESC and motor
The motor stop running while in working state	Throttle signal is lost	Check the receiver and transmitter Check the cable of throttle channel
	ESC has entered Low Voltage Protection mode	Land RC model as soon as possible, and then replace the battery pack
	Some connections are not reliable	Check all the connections: battery pack connection, throttle signal cable, motor connections, etc.
Random stop or restart or irregular working state	There is strong electro-magnetic interference in flying field.	Reset the ESC to resume normal operation. If the function could not resume, you might need to move to another area to fly.

Manual of Brushless Motor Speed Controller

Normal startup procedure:

Move throttle stick to bottom and then switch on transmitter.	Connect battery pack to ESC, special tone like "♪123" means power supply is OK	Several "beep-" tones should be emitted, presenting the number of lithium battery cells	When self-test is finished, a long "beep-----"tone should be emitted	Move throttle stick upwards to go flying
---	--	---	--	--

Throttle range setting: (Throttle range should be reset whenever a new transmitter is being used)

Switch on transmitter, move throttle stick to top	Connect battery pack to ESC, and wait for about 2 seconds	"Beep-Beep-" tone should be emitted, means throttle range highest point has been correctly confirmed	Move throttle stick to the bottom, several "beep-" tones should be emitted, presenting the number of battery cells	A long "Beep-" tone should be emitted, means throttle range lowest point has been correctly confirmed
---	---	--	--	---

Program the ESC with your transmitter (4 Steps):

1. Enter program mode
2. Select programmable items
3. Set item's value (Programmable value)
4. Exit program mode

1. Enter program mode

- 1) Switch on transmitter, move throttle stick to top, connect the battery pack to ESC
- 2) Wait for 2 seconds, the motor should emit special tone like "beep-beep-"
- 3) Wait for another 5 seconds, special tone like "♪567i2" should be emitted, which means program mode is entered

2. Select programmable items:

After entering program mode, you will hear 8 tones in a loop with the following sequence. If you move the throttle stick to bottom within 3 seconds after one kind of tones, this item will be selected.

1. "beep"	brake	(1 short tone)
2. "beep-beep"	battery type	(2 short tone)
3. "beep-beep-beep"	cutoff mode	(3 short tone)
4. "beep-beep-beep-beep"	cutoff threshold	(4 short tone)
5. "beep-----"	startup mode	(1 long tone)
6. "beep-----beep"	timing	(1 long 1 short)
7. "beep-----beep-beep"	set all to default	(1 long 2 short)
8. "beep-----beep-----"	exit	(2 long tone)

Note: 1 long "beep-----" = 5 short "beep-"

3. Set item value (Programmable value):

You will hear several tones in loop. Set the value matching to a tone by moving throttle stick to top when you hear the tone, then a special tone "♪i5i5" emits, means the value is set and saved. (Keeping the throttle stick at top, you will go back to step 2 and you can select other items; Moving the stick to bottom within 2 seconds will exit program mode directly)

Items	Tones		
	"beep-" 1 short tone	"beep-beep-" 2 short tones	"beep-beep-beep" 3 short tones
Brake	Off	On	
Battery type	Li-ion / Li-poly	NiMH / NiCd	
Cutoff mode	Soft-Cut	Cut-Off	
Cutoff threshold	Low	Medium	High
Start mode	Normal	Soft	Super soft
Timing	Low	Medium	High

4. Exit program mode

There are 2 ways to exit program mode:

1. In step 3, after special tone "♪i5i5", please move throttle stick to the bottom position within 2 seconds.
2. In step 2, after tone "beep-----beep-----"(ie. The item #8), move throttle stick to bottom within 3 seconds.

How to enter the programming mode of the Dynam's brushless ESC with the Dynam 2.4Ghz radio system:

(Warning: Please disconnect the motor from the ESC before starting the following procedure)

- 1) Turn on the transmitter, then connect battery to the receiver, let the normal auto binding process completed. (Both LED lights on transmitter and receiver should flash rapidly at the same time for this process to succeed)
- 2) Disconnect the receive power; **do not turn off the transmitter.**
- 3) Move the throttle stick to the top position.
- 4) Toggle the safety switch (on the upper left hand corner of the transmitter). Then make sure the safety switch is at the off position (the tip of the switch is set toward the back of the transmitter)
- 5) Connect battery to the receiver; now you are ready to enter the programming mode (please see the ESC manual for programming instruction).
- 6) If unable to enter the programming mode, please repeat the above procedure again.

Decal

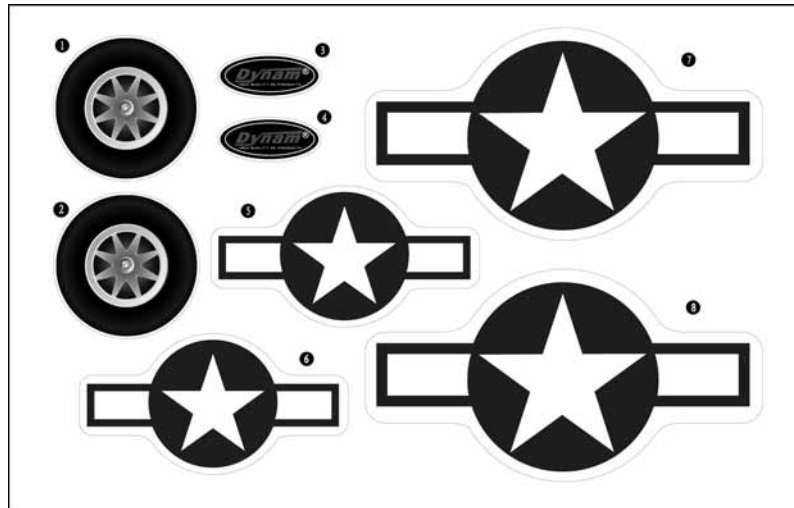

Open the canopy

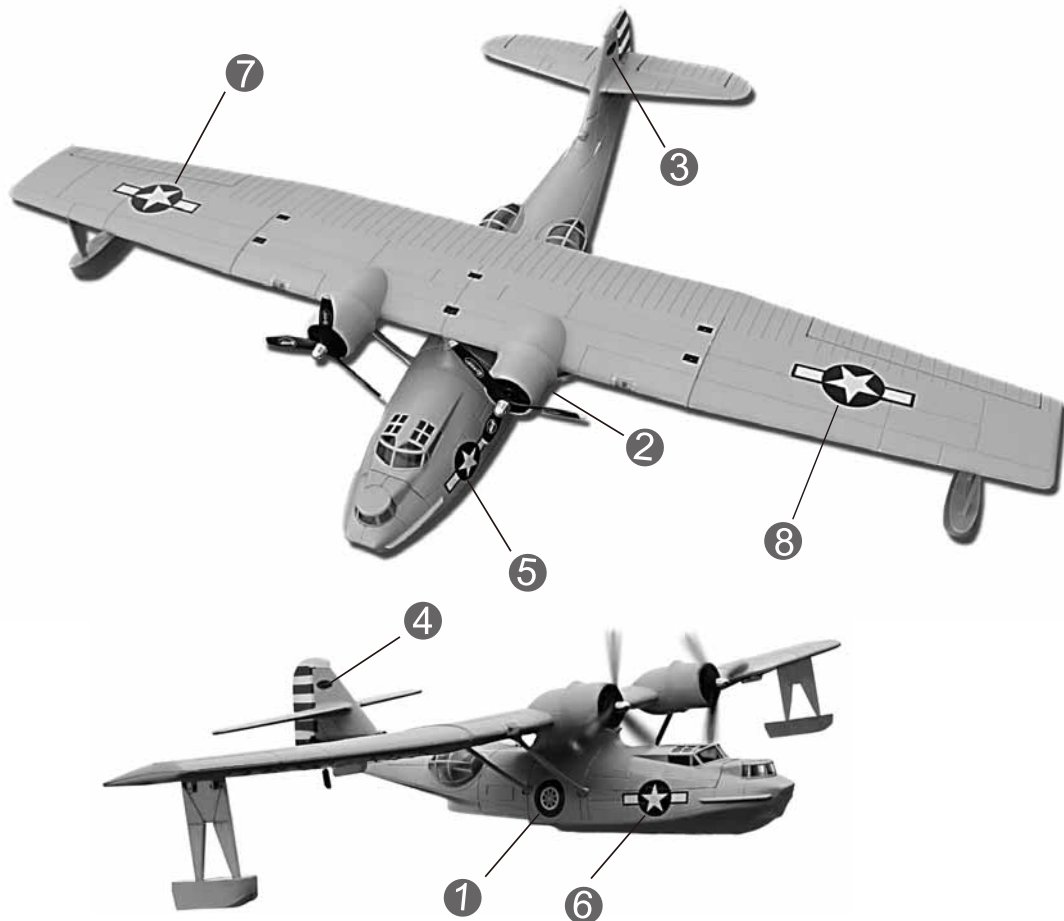

Battery Warning And Charging

Lithium-polymer batteries are a revolutionary new rechargeable battery technology for electric R/C flight, offering a variety of significant advantages over NiCd, NiMH and Li-Ion batteries. It is very important to have a good understanding of the operating characteristics of Li-Po batteries especially their exact rated voltage. Always read the specifications printed on the label of your Li-Po battery prior to use, and read this instruction sheet in its entirety.

WARNING! Lithium-Polymer batteries (Li-Po) are entirely different than NiCd and NiMH batteries and must be handled differently as well!! Failure to follow these care and handling instructions can quickly result in severe, permanent damage to the batteries and its surroundings and even start a FIRE!

- You must charge the Li-Po battery pack in a safe area away from flammable materials.
- Never charge the battery unattended. When charging the battery you should always remain in constant observation to monitor the charging process and react to potential problems that may occur.
- After flight, the battery cool down to ambient temperature before charging.
- Wire lead shorts can cause fire! If you accidentally short the wires, the battery must be placed in a safe area for observation for approximately 15 minutes.



- In the event of a crash, you must quickly and safely disconnect and remove the battery from observation, then place it in a safe, open area away from flammable materials to observe it for at least 15 minutes.
- Store the battery at room temperature for best results.
- Do not over-discharge the battery. Discharging the battery too low can cause damage to the pack resulting in reduced performance and duration.

Battery Warning And Charging

The charger requires up to 1.5 Amps of 10-15 Volt DC input power that can be supplied from a small 12V gel cell or car battery.

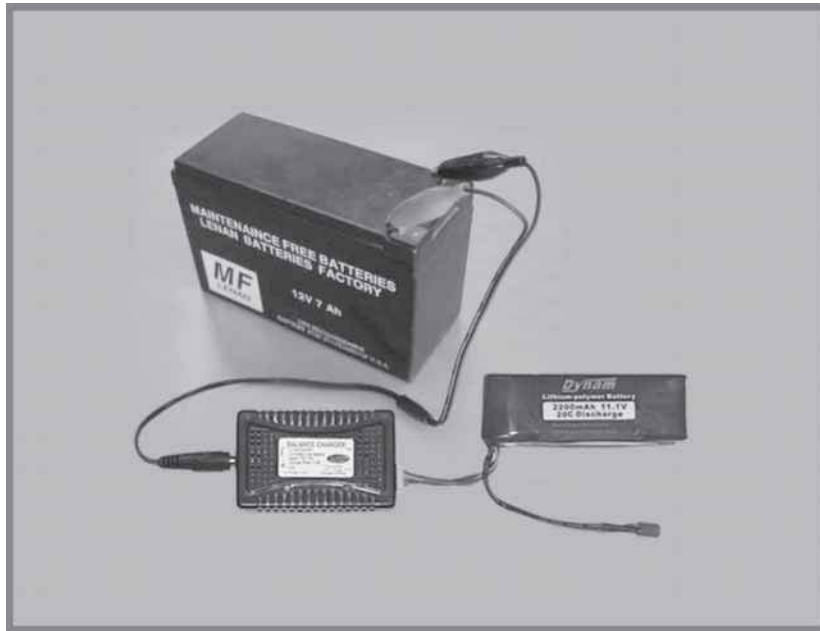

Input power for the charger can also be supplied through the use of an AC to DC adapter/power supply for convenient charging anywhere an AC outlet is available. We recommend the optional AC to 12V DC, 1.5 Amp Power Supply. **NEVER attempt to power the charger from an AC outlet without the use of a proper AC to DC adapter/power supply.**



Battery Warning And Charging

Once you have connected the charger to a power source, The red LED will turn on. Connect the Li-Po battery pack to the charger. When the pack is full charged. The green LED will turn on.

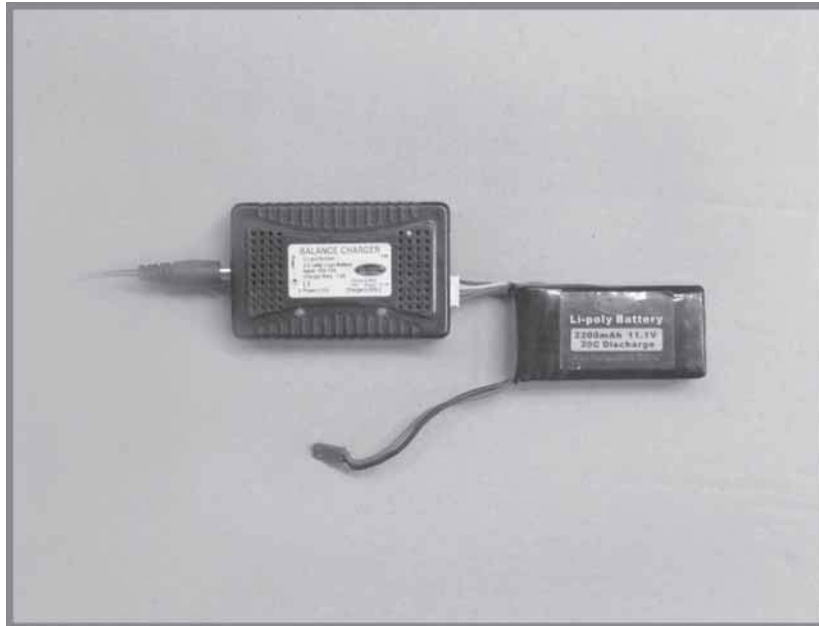

Install the Transmitter Batteries

Install 8 new "AA" batteries in the included transmitter. Check the power level of the batteries and operation of the transmitter by switching the power switch on (upward). The status LEDs at the top of the transmitter will indicate the power level of the batteries. If at any time the status LEDs no longer show green, it will be necessary to replace the batteries with new ones.



Parts List

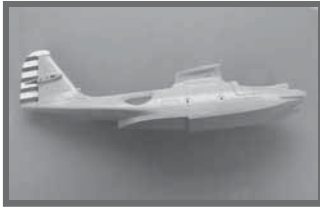

CTL-01 Fuselage



CTL-02 Side wing set

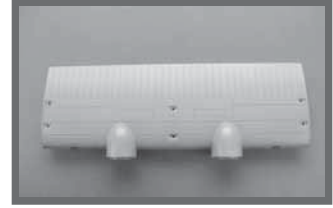

CTL-03 Middle wing set



CTL-04 Float



CTL-05 Blister parts



CTL-06 Propeller



CTL-07 Brushless Motor



CTL-08 Push rod

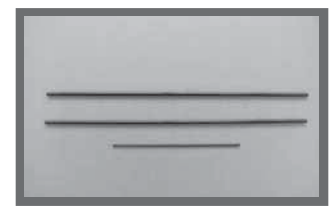

CTL-09 Bolt Pipe



CTL-10 Wing struts set



DYAT-008 Servo Horn



DY-3001 quick-controller



DY-1007 9g Servo



DYA-000X Adaptor



DY-6006 11.1V 2200mAh 20C Li-Po Battery



DYT-2002 Transmitter



DYC-1002 Balance Charger

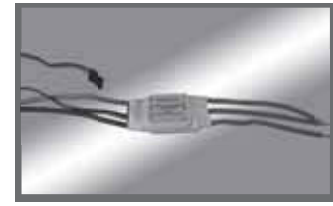

DYE-1003 30A ESC



DYR-2001 2.4G Receiver



DY-3003 Glue

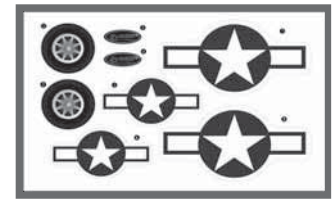

CTL-11 DECAL



F-16

Specification: INSTRUCTION MANUAL

Wingspan: ----- 670mm
 Fuselage length: ----- 1020mm
 Wing loading: ----- 47g/dm²
 Flying weight: ----- 650g
 Servo: ----- 9g
 Battery: ----- 11.1V 2200mAh 15C Li-Po
 ESC: ----- 60A
 Brushless Outrunner Motor: ----- KV:4400
 Ducted fan: ----- EDF 64mm



SKYBUS

Specification: INSTRUCTION MANUAL

Wingspan:----- 1470mm
 Fuselage length: 980mm
 Wing Area: ----- 24.6dm²
 Wing loading: ----- 48.8g/dm²
 Flying weight: ----- 1200g
 Servo: ----- 9g x 4
 Battery: ----- 11.1V 2200mAh 15C Li-Po
 ESC: ----- 40A x 2
 Brushless Outrunner Motor: KV1100



CESSNA EP 400

Specification: INSTRUCTION MANUAL

Length..... 30in
Wing Span..... 37.8in
Wing Area..... 15.3dm²
Flying Weight..... 430g
Wing Loading..... 28.1g/dm²

visit our website www.dynam-rc.cn



www.dynam-rc.cn

迪乐美

Dynam RC Hobby Co.,Ltd



Home
About us
Download
News
Contact us

Dynam RC Hobby Co., Ltd.



740-V7555185

F-51D Mustang







Specification:	
Wingspan:	47 in (1200mm)
Overall Length:	41 in (1045mm)
Flying weight:	38.8oz (1100 g)
Servo:	9g 4pcs include
Battery:	3S 11.1V 2200mAh Li-Po .20
Speed Control:	30A brushless
Motor Size:	850Kv Brushless Outrunner
Charger:	3-cell Li-Po balancing

Catalog

- Airplanes >
- Helicopters >
- Rc Electronics >
- Esc >
- Charger >
- Motor >
- Battery >
- Combos >
- Blade >



NEW



NEW



NEW



NEW



NEW



NEW

- TEL:+86-769-87566018 • E-mail:sales@dynam-rc.cn
- FAX:+86-769-87555185 • Http:www.dynam-rc.cn
- Add:No.C-02 Nanshan Industry Town Yantian Fenggang
City Dongguan Guangdong Province